

M/1500 Exhaust filter



- > Port size: G1/8 ... G1
- > Robust and compact
- > Prevent the ingress of dirt with minimal flow restriction
- > Screw directly into the exhaust port



Technical features

Medium:

Compressed air, filtered, lubricated or non-lubricated, inert gases

Operation:

Exhaust filter

Operating pressure:

10 bar (145 psi) max.

Port size:

G1/8, G1/4, G1/2, G3/4, G1

Mounting:

Directly in the exhaust port

Ambient/Media temperature:

-20°C ... +80°C (-4 ... +176°F)

Air supply must be dry enough to avoid ice formation at temperatures below +2°C (+35°F).

Materials:

Body: aluminium alloy

Element: sintered bronze

Technical data

Symbol	Port size	Flow factor C *1)	Cv	Kv *2)	Weight (kg)	Model
	G 1/8	2	0,49	0,426	0,006	M/1511
	G 1/4	5,6	1,37	1,19	0,018	M/1512
	G 1/2	11,2	2,75	2,39	0,030	M/1514
	G 3/4	20,6	5,05	4,39	0,050	M/1516
	G 1	26,4	6,47	5,62	0,091	M/1518

*1) Measured in m³/(s. bar)

*2) Measured in m³/h

Option selector

M/151★

Port size	Substitute
1/8"	1
1/4"	2
1/2"	4
3/4"	6
1"	8

Dimensions

Dimensions in mm
Projection/First angle

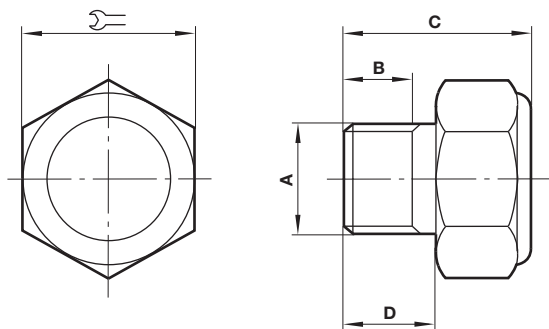

A	B	C	D		Model
G 1/8	6	16	8	15	M/1511
G 1/4	8	22	10	23,5	M/1512
G 1/2	10,5	25	13	30,5	M/1514
G 3/4	14	31	16	42,5	M/1516
G 1	15	35	19	47	M/1518

Warning

These products are intended for use in industrial compressed air systems only. Do not use these products where pressures and temperatures can exceed those listed under »**Technical features/ data**«.

Before using these products with fluids other than those specified, for non-industrial applications, life-support systems or other applications not within published specifications, consult Norgren.

Through misuse, age, or malfunction, components used in fluid power systems can fail in various modes.

The system designer is warned to consider the failure modes of all component parts used in fluid power systems and to provide adequate safeguards to prevent personal injury or damage to equipment in the event of such failure.

System designers must provide a warning to end users in the system instructional manual if protection against a failure mode cannot be adequately provided.

System designers and end users are cautioned to review specific warnings found in instruction sheets packed and shipped with these products.