

VT series Ball Valve for Rail Applications

Installation and Maintenance Instructions



EN For further information, scan this QR code or visit www.imi-precision.com



OPTION SELECTOR

SERIES SIZE	Substitute	VT * * * * *	2 * *	Thread type	Substitute
DN 15	20			PTF	A
DN 20	30			R50 Rc	B
DN 25	40			G THREAD	G
DN 32	50			NO THREAD	N
THREAD SIZE	Substitute			HANDLE	Substitute
1/2" (DN 15)	4			NO HANDLE	N
3/4" (DN 20)	6			LEVER HANDLE	L
1" (DN 25)	8			WHITE	H
1 1/4" (DN 32)	A			BLACK	J
R50 thread (DN 15, DN 25)	R			RED	K
MONITORING OPTION	Substitute			YELLOW	L
NO MONITORING	1			LATCHING HANDLE	Substitute
OPEN POSITION	2			WHITE	O
CLOSE POSITION	3			BLACK	P
OPEN/OPEN POSITION	4			RED	R
CLOSE/CLOSE POSITION	5			YELLOW	S
OPEN/CLOSE POSITION	6			PORT AND LOCKING	Substitute
CLOSE/OPEN POSITION	7			IN-LINE	F
HANDLE POSITIONING	Substitute			NO LOCK	F
1 OPEN; 2 CLOSE	0			LOCK CLOSED	G
1 CLOSE; 2 OPEN	1			LOCK CLOSED AND OPEN	H
3 OPEN; 4 CLOSE	2			INTERFACE	D
3 CLOSE; 4 OPEN	3			NO LOCK	D
4 CLOSE; 1 OPEN	4			LOCK CLOSED	E
				LOCK CLOSED AND OPEN	C

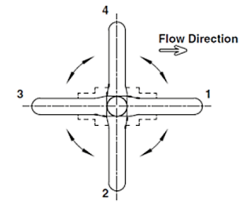

TECHNICAL DATA

Fluid: Compressed air
 Working pressure: 10 bar (146 psig)
 Maximum pressure: 12 bar (175 psig)
 Storage temperature: -55 °C to +85 °C (-67 ° to 185 °F)
 Operating temperature*: -40 °C to +85 °C (-40 ° to 185 °F)
 * Air supply must be dry enough to avoid ice formation at temperatures below +2 °C (+35 °F)
 Materials: Body, end connectors and handles: Aluminium
 Seat: PTFE
 'O'-rings: Synthetic Rubber
 Ball, Stem: Brass
 Screws: Steel

REPLACEMENT ITEM

Service kit
(items circled on exploded view)

SERIES SIZE	Substitute	V T * * * - K I T A *	INTERFACE	Substitute
DN 15	20		IN-LINE	F
DN 20	30		MANIFOLD	N
DN 25	40			
DN 32	50			

SERIES SIZE	Substitute	V T * * * - K I T *	HANDLE POSITION	Substitute
DN 15	20		1 OPEN; 2 CLOSE	A
DN 20	30		1 CLOSE; 2 OPEN	B
DN 25	40		3 OPEN; 4 CLOSE/4 CLOSE; 1 OPEN	C
DN 32	50			
TYPE OF HANDLE	Substitute		HANDLE COLOUR	Substitute
LEVER HANDLE KIT	B		WHITE	W
LATCHING HANDLE KIT	C		BLACK	B
LATCHING HANDLE + LOCKING KIT	D		RED	R
			YELLOW	Y

EXTERNAL SWITCH KIT
V T X X - K I T E

VT40 – INTERFACE VERSION

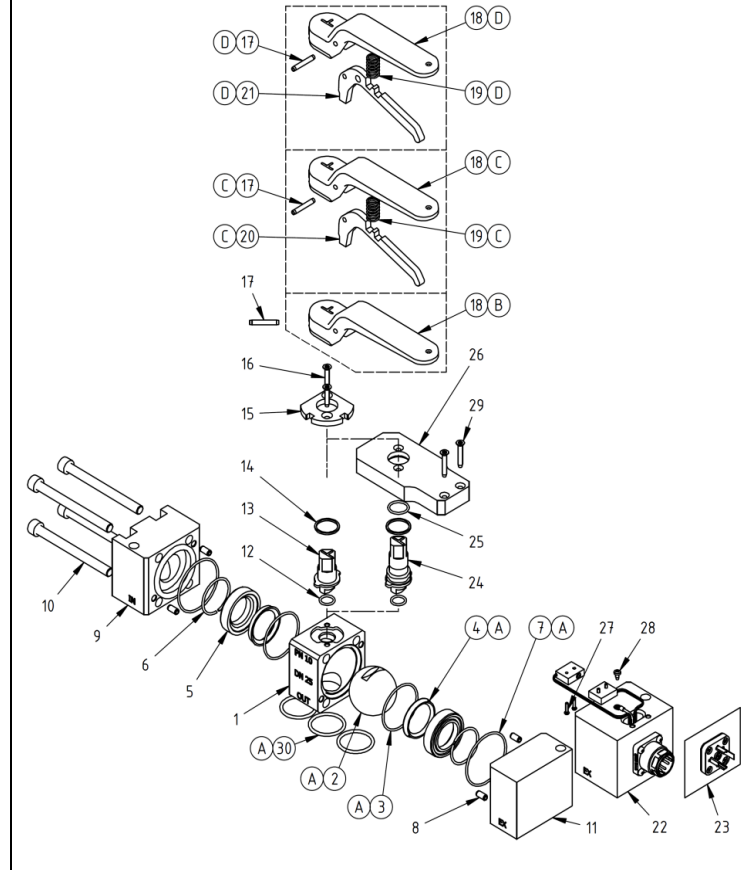

BALL VALVE POSITION - IN-LINE SERIES

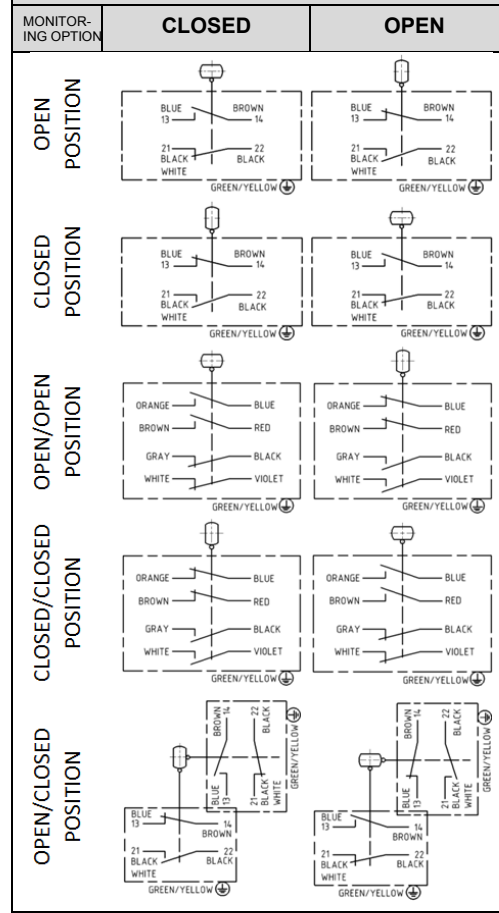

INSTALLATION

The ball valve must be connected to the system so it respects the direction of flow shown on the body of ball valve. The plugs must be removed before use.

Inline Mounted Valves

Use pipe thread sealant on male threads only. Do not allow sealant to enter interior of valve

Flange Mounted Valves

Attach valve to flange using screws + insert o-rings from attachment.

Disassembly

1. Shut off inlet pressure. Reduce pressure in inlet and outlet lines to zero.
2. Remove the valve from the air line. Disassemble in general accordance with item numbers on exploded view.

Cleaning

1. Clean all parts with warm water and soap.
2. Dry and inspect parts. Replace parts found to be damaged.

Assembly

1. Lubricate o-rings and seats (item 3, 4, 7, 30) with light coat suitable grease with temperature range -40°C to +85°C (the grease should be based on synthetic hydrocarbon oil and calcium soap).
2. Assemble the unit as shown on the exploded view. Ball (item 2) must be assembled so the drilled hole can be seen in the outlet when the handle is in the closed position.

Locking handle

Padlock with following recommended dimensions is to be used to lock the latching handle.

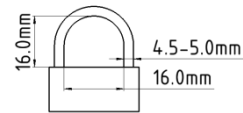

WARNINGS

These products are intended for general usage primarily for Rail sector. Do not use these products where pressures and temperatures can exceed those listed under Technical Data. Before using these products with fluids other than air, consult IMI Precision Engineering. The ball valve is meant to open/close working fluid supply, not for flow regulation. Electric monitoring provides information about actual working status just in end positions. This signal is for information only and should not be used as a safety signal. Before disassembling of device placed behind the valve, the operator needs to check the system is depressurized by separate pressure indicator (e.g. pressure switch), even the signal from monitoring shows closed position of the valve. The valve equipped by electrical monitoring needs to be grounded to ensure proper protection against electric shock. End user is responsible for correct grounding and wire protection against damage.

INLINE SERIES

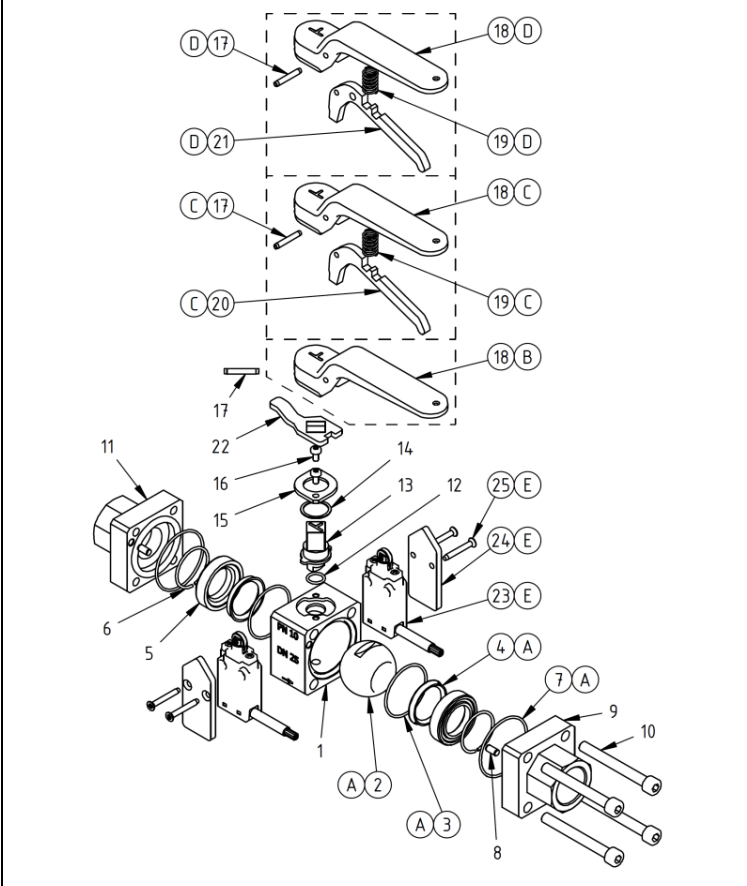

VT20 – INTERFACE VERSION

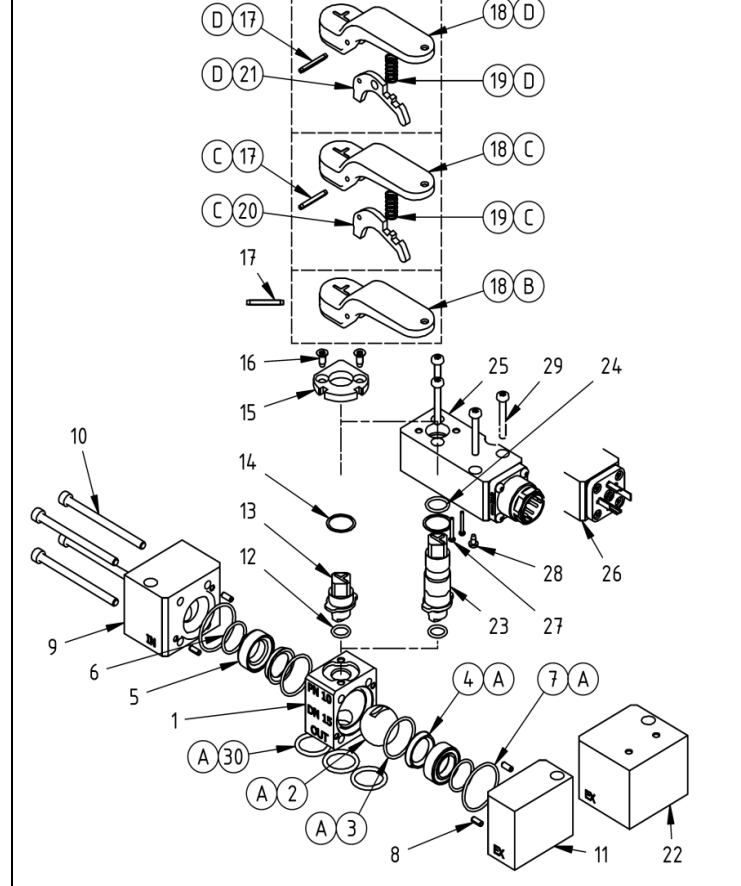

BALL VALVE POSITION - INTERFACE SERIES

