

- > Designed for use with Cadent™ 3 syringe pumps
- > Rated to 80 psig (5.52 barg)
- > Available in various volumes, materials and tip styles
- > Suitable for use in analytical, biotechnology and diagnostic applications



Specifications

Physical

Length (Dispensed):

2.37"

Thread Type:

¼-28 UNF-2A

Test Pressure:

80 psig (5.52 barg)

Life cycle (Minimum):

100,000

Tested with DI water using IMI standard protocol

Environmental

Operating Temperature:

10°C to 40°C (50°F to 104°F)

Storage Temperature:

-33°C to 71°C (-27°F to 160°F)

Relative Humidity:

Up to 100%

Chemical

Wetted Materials:

Borosilicate glass, PCTFE, PTFE (or UHMW-PE)

Syringe Tips:

Lubricated with laboratory grade silicone

Mechanical Specifications

Kloehn™ Syringe Sizes	50µL	100µL	250µL	500µL	1.0mL	2.5mL	5.0mL
Orifice Size (in)	0.023	0.023	0.031	0.031	0.073	0.073	0.073
Syringe(End Cap) Diameter (in)	0.43	0.43	0.43	0.43	0.43	0.56	0.72
Button Diameter (in)	0.25	0.25	0.25	0.25	0.3	0.3	0.3
Max Drag Force* (lbs)	PTFE	3.0	3.0	3.0	3.0	6.0	6.0
	UHMW	7.0	7.0	7.0	7.0	10.0	10.0

*Add 1 pound (lbs) drag force for non-lubricated plunger tip syringes. Installation torque = 20oz-in

Kloehn™ Syringe Anatomy

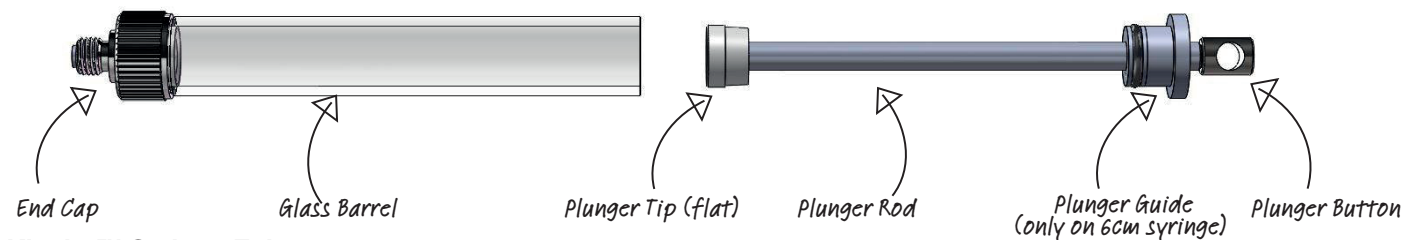

Kloehn™ Syringe Enhancements



Zero Dead Volume Plunger Tip

Kloehn™ Syringes are available with an enhanced Zero Dead Volume (ZDV) plunger tip. These tips have a pointed end and extend into the end cap, providing a fully swept wetted path, minimizing the presence of residual fluids to address cross-contamination or carryover into subsequent operations.

Both flat and ZDV plunger tips can be supplied in either PTFE, a chemically inert material offering high durability, or UHMW-PE, offering high impact strength and suitable for use with fluids containing particulate.



Glass Barrel Shrink Wrap

For increased safety when using Kloehn™ syringes in high pressure environments, the syringes can be supplied with a shrink-wrapped glass barrel.

This enhancement is available on request and can be applied to any syringe volume dispense size.

For other customization requests, contact us at IMIKloehn™customersupport@imi-precision.com

PTFE Kloehn™ Syringes (individually boxed):

Dispense Volume	Orifice Size (in)	Standard Lubricated Syringe	Non-Lubricated Syringe	ZDV Syringe (Lubricated)
50µL	0.023	23164	22007	27960
100µL	0.023	23165	22008	27961
250µL	0.031	23166	22009	28006
500µL	0.031	23167	22010	28007
1.0mL	0.073	23168	22011	28008
2.5mL	0.073	23169	22012	28009
5.0mL	0.073	23170	22013	28010

Wetted materials: Borosilicate glass, PCTFE, UHMW-PE, PTFE

UHMW Kloehn™ Syringes (individually boxed):

Dispense Volume	Orifice Size (in)	Standard Lubricated Syringe	Non-Lubricated Syringe	ZDV Syringe (Lubricated)
50µL	0.023	24411	*	27958
100µL	0.023	24412	*	27959
250µL	0.031	24413	*	28011
500µL	0.031	24414	*	28012
1.0mL	0.073	24415	*	28013
2.5mL	0.073	24416	*	28014
5.0mL	0.073	24417	*	28015

Wetted materials: Borosilicate glass, UHMW-PE, PTFE

* Available upon request

Dimensions in inches [mm]
1mL syringe shown

Third Angle Projection

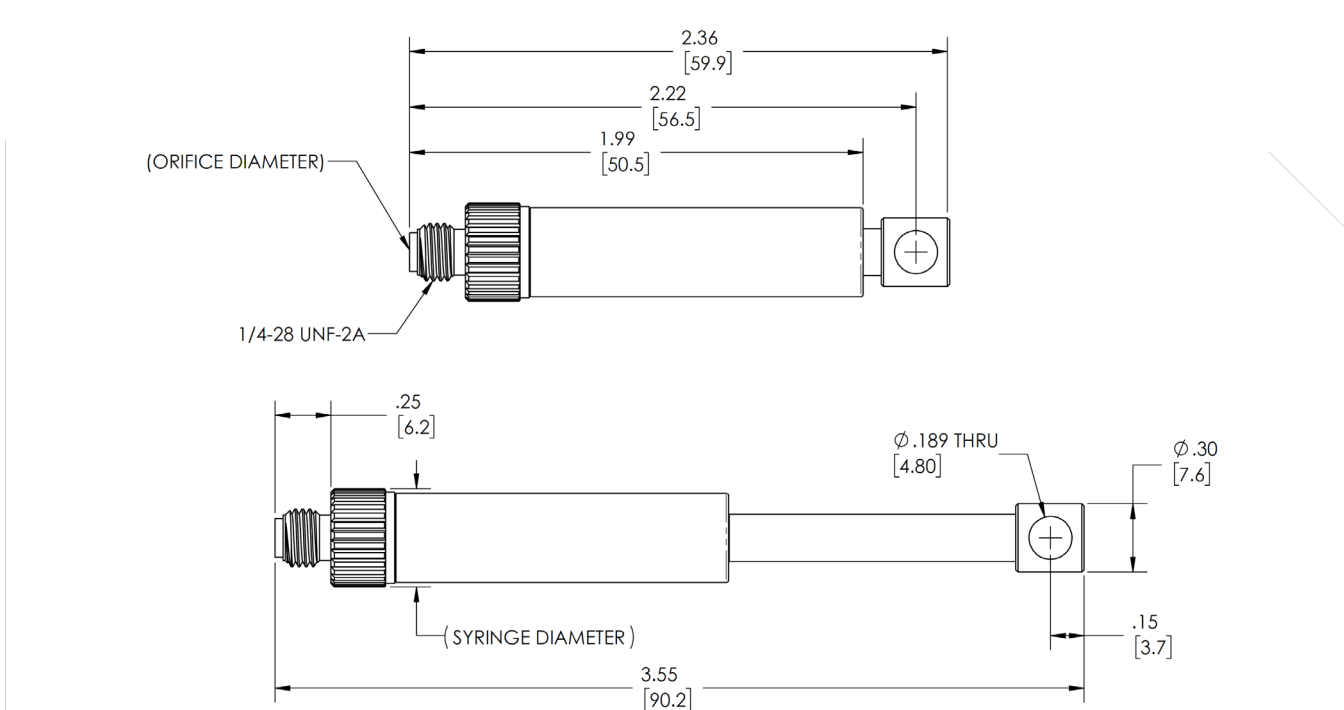

Warning

Improper selection, misuse, age or malfunction of components used in systems can cause failure in various modes. The system designer is warned to consider the failure modes of all component parts and to provide adequate safeguards to prevent personal injury or damage to equipment or property in the event of such failure modes. System designers and end-users are cautioned to consult instruction sheets and specifications available from the factory. The system designer/end-user is responsible for verifying that all requirements for the application are met. Due to unlimited application, system conditions and chemistries, it is the buyers responsibility to validate the product within their specific application.

Proposition 65: These products may contain chemicals known to the state of California to cause cancer, or birth defects, or other reproductive harm.