

## Excelon® Plus

**Air Preparation Range**  
**1/4", 3/8" 82 Series**  
**3/8", 1/2", 3/4" 84 Series**

### Installation and Maintenance Instructions



CN – 欲了解更多信息和其他语言版本，请扫描二维码。  
 DE – Für weiterführende Informationen diesen QR-Code scannen oder siehe:  
 ES – Para más información y otros idiomas, escanear este código QR o visitar:  
 FR – Pour plus d'informations et d'autres langues, consultez ce code QR ou visitez:  
 IT – Per ulteriori informazioni e altre lingue scansionare questo QR code o visitare:  
 PT – Para mais informação e outros idiomas scaneie este código QR ou visite a:  
 RU – Для получения более подробной информации, в том числе на других языках, пожалуйста, отсканируйте QR код или посетите :  
[www.norgren.com/excelon-plus](http://www.norgren.com/excelon-plus)

**Excelon® Plus TR series:**  
**Part numbers preceded by the letter L are validated for Rail Applications.**  
**Part numbers preceded by the letter H have a broader application temperature range for industrial application**  
 L variants (Rail Approved) -40° to +80 °(-40F ° to 176F °)  
 H variants (Extreme Temp.) -40° to +80 °(-40F ° to 176F °)  
 unless otherwise stated on the product label.

For Technical Data see the data sheets on [www.norgren.com](http://www.norgren.com)



**II 2 GD**  
**Ex h IIC T6 Gb**  
**Ex h IIC T85°C Db**

\* See overleaf for ATEX declaration of conformity. ATEX does not apply to B84, R84 and Q84 units with Integrated Electronic Pressure Switches.

### CAUTION

Water vapour will pass through these units and could condense into a liquid form downstream as air temperature drops. Install an air dryer if water condensation could have a detrimental effect on the application.

Installation, commissioning, disassembling as well as repair and maintenance must only be carried out by qualified specialized personnel with expertise and experience on pneumatic technology and in case of electrical devices also electrical technology.

### WARNINGS

- These products are intended for use in industrial compressed air systems only. Do not use these products where pressures and temperatures can exceed those listed under Technical Data.
- Polycarbonate plastic bowls can be damaged and possibly burst if exposed to such substances as certain solvents, strong alkalis, compressor oils containing ester-based additives or synthetic oils. Fumes of these substances in contact with the polycarbonate bowl, externally or internally, can result in damage.
- Use metal bowl in applications where a plastic bowl might be exposed to substances that are incompatible with polycarbonate.
- An outlet pressure more than the pressure setting could cause downstream equipment to rupture or malfunction. Install a pressure relief device downstream of the filter-regulator/regulator. Do not modify or interfere with the adjusting mechanism.
- The relief pressure and flow capacity of the relief device must satisfy system requirements.
- The accuracy of the indication of pressure gauges can change both during shipment (despite care in packaging), and during the service life. Ensure the gauge readings are accurate if a pressure gauge is to be used with these products and if inaccurate indications may be hazardous to personnel or property.
- See separate product specific manual for Integrated Electronic Pressure Switch installation, operation and repair.
- Before using these products with fluids other than air, non-industrial applications or for life-support systems, consult Norgren.

### GENERAL INSTALLATION

- GI-1 Always turn off and exhaust air pressure prior to installing and servicing units. Ensure that the air is completely exhausted prior to beginning any actions.
- GI-2 Connect piping to ports using pipe thread sealant on male threads only. Do not allow sealant to enter the interior of the unit. Units should be installed with air flow in the direction of the arrow on the body and as close as possible to the device being serviced.
- GI-3 Install filters:  
 GI-3.1 Upstream of regulators, lubricators, and cycling valves and oriented vertically
- GI-4 Install regulators:  
 GI-4.1 Upstream of lubricators and cycling valves, and downstream of filters
- GI-5 Install filter/regulators:  
 Upstream of lubricators and cycling valves, downstream of filters, and oriented vertically
- GI-6 Install lubricators:  
 GI-6.1 Upstream of cycling valves and oriented vertically  
 GI-6.2 Install oil-fog lubricator no more than 15 feet (4.6m) from the devices being lubricated and at the same height or higher than the device being serviced
- GI-7 Special considerations for units with a/an:  
 GI-7.1 Automatic drain:  
  - Automatic drain flexible tube requires a minimum internal diameter of 5 mm (3/16"). Drain may fail to operate if the tube ID is less than 5 mm. Avoid restrictions in the tube.
 GI-7.2 Gauge port:  
  - Install a pressure gauge or plug the gauge port if no gauge is present.
 GI-7.3 Bowl:  
  - Ensure the clip and cover arrows are aligned before pressurizing.

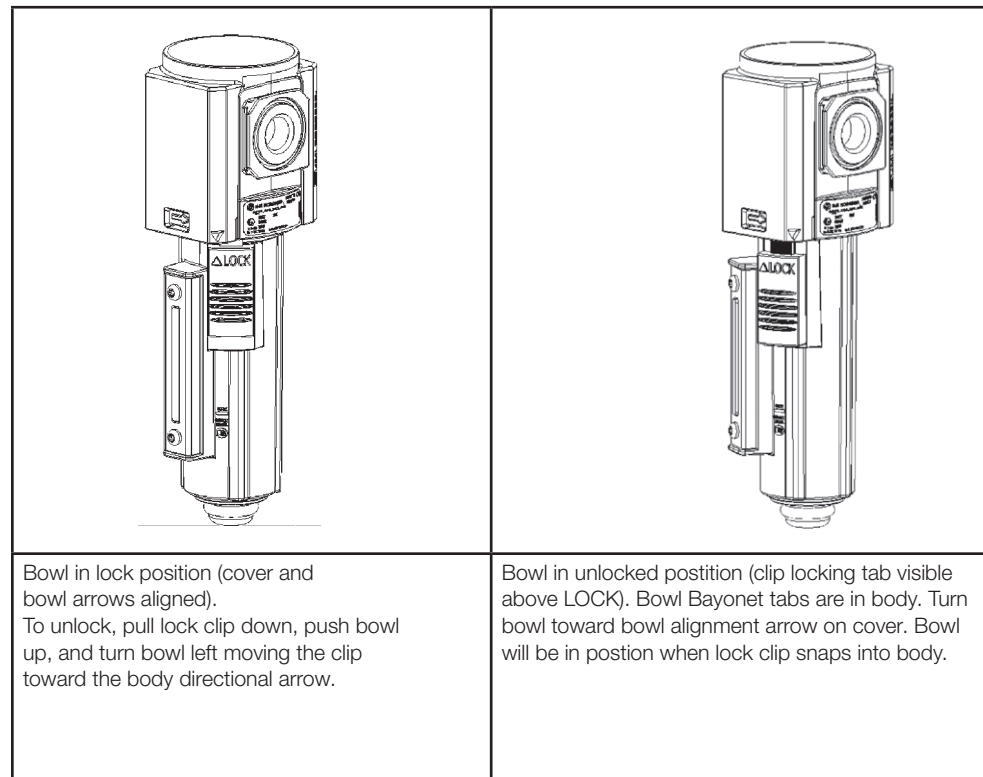

### Shut-off Valve

#### Tamper Proofing

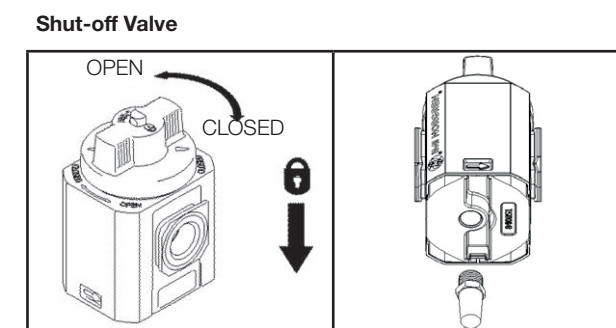

Accessories – 84/82 Series	
Part No.	Description
840055-01KIT	Padlock kit
840055-02KIT	Hasp lock-out device

- SO-1 To isolate the supply pressure and exhaust the downstream pressure, rotate the knob from the open to the closed position.
- SO-2 To lock the valve in the closed position, push the knob down and apply a hasp or padlock.
- SO-3 To reduce noise and keep contamination out of the unit, installing an exhaust muffler into the bottom port is recommended.

### Filter & Filter/Regulator

#### Install filters:

Upstream of regulators, lubricators, and cycling valves and oriented vertically

#### SERVICING

Service kits for each series are listed in table 1 below. See illustrations below. Note, any replacement O-ring seals should be lubricated. See Norgren website for recommended lubricants. Use QR code or web link.

#### Servicing-Filter replacement

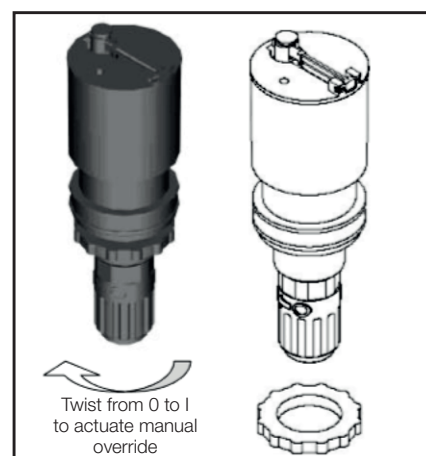
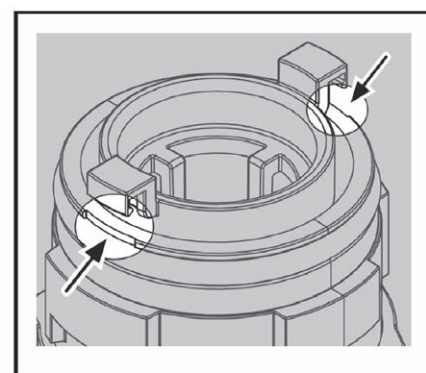
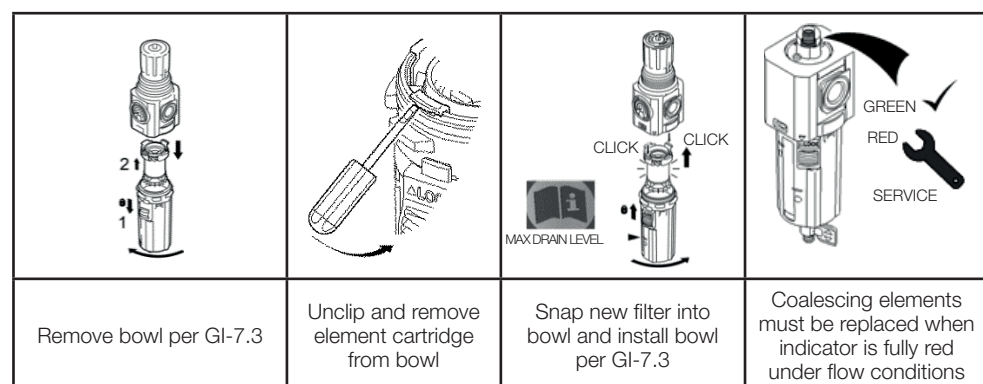

#### Operating Manual Drain or Automatic Drain Override

Rotate the manual drain 1/4 turn to expel accumulated liquids.

Keep liquids below the baffle (max level identified on bowl).

If needed, rotate the manual override section of the automatic drain per drain override arrow to expel liquids.

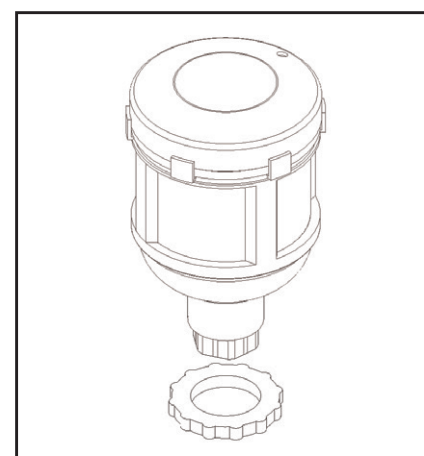

#### Auto-Drain Version L-variant (Rail approved) and H-variant( Extreme Temp.)

Exhaust Valve pin (inside bottom connector) can be pushed from below to override and lift the float to expel liquids.

#### Servicing-Automatic Drain Replacement

- F-1 Remove bowl per GI-7.3
- F-2 Remove filter element.
- F-3 Remove the retaining nut, auto-drain assembly, and gasket.
- F-4 Replace the auto-drain assembly with the correct service kit, ensuring that the gasket is located between the auto-drain assembly and bowl.
- F-5 Hand thread and torque the retaining nut to 20.0-25.0 in-lb (2.26-2.82 Nm).
- F-6 Replace element and install bowl per GI-7.3

#### Spare Parts: Bowls

Standard 82 Series	Standard 84 Series	Description
820025-51KIT	840025-51KIT	Guarded Poly bowl with auto drain 6mm PIF
820025-50KIT	840025-50KIT	Guarded Poly bowl with manual drain
820003-51KIT	840003-51KIT	Metal bowl S/Glass with auto drain 6mm PIF
820003-51KIT	840003-51KIT	Metal bowl S/Glass with manual drain
820025-53KIT	840025-53KIT	Guarded Poly bowl with auto drain 1/4"PIF
820003-56KIT	840003-56KIT	Metal bowl S/Glass with auto drain 1/4" PIF

For replacement bowls required for part numbers preceded by a H or L please contact the factory

#### Replacement Elements for Filters & Filter Regulators

	82 Series	84 Series	L Version (Rail Approved)	H Version (Extreme Temp.)
5 µm element	820038-50KIT	840038-50KIT	L840038-50KIT	H840038-50KIT
40 µm element	820038-51KIT	840038-51KIT	L840038-51KIT	H840038-51KIT
Coalescing cartridge element	820044-50KIT	840044-50KIT	L840044-50KIT	H840044-50KIT
Vapour removal cartridge element	820041-50KIT	840041-50KIT	L840041-50KIT	H840041-50KIT

#### Replacement drain types for Filters & Filter Regulators

Series	Automatic Drain	Manual drain
Standard (82 & 84 Series)	6000-**	N/A
Preceded by 'L'	3000-40	684-85
Preceded by 'H'	3000-40	684-85

\*\* = 61 for 1/4" OD PIF

\*\* = 60 for 6mm OD PIF

All Variants preceded by 'L' are validated for use in rail applications.

Shock & Vibration tested to EN61373, Cat. I A&B and Cat. II

### Regulator & Filter/Regulator

#### Install regulators:

Upstream of lubricators, cycling valves and downstream of filters

#### ADJUSTMENT (Regulator and filter-regulator)

- R-1 Before applying inlet pressure, pull the adjusting knob up (exposing the red indicator ring) and turn the adjusting knob in the minus direction to remove all force on the regulating spring.
- R-2 Apply inlet pressure, then turn the adjusting knob the direction indicated on the knob to adjust the pressure setting.
- R-3 Always approach the desired pressure from a lower pressure. When reducing from a higher to a lower setting, first reduce to some pressure less than that desired, then bring up to the desired pressure.
- R-4 Once the required pressure is achieved, push the knob down (red indicator ring covered) to lock pressure and apply a padlock if required. For T-bar adjustment, tighten lock-nut to lock pressure setting.

#### Tamper proofing

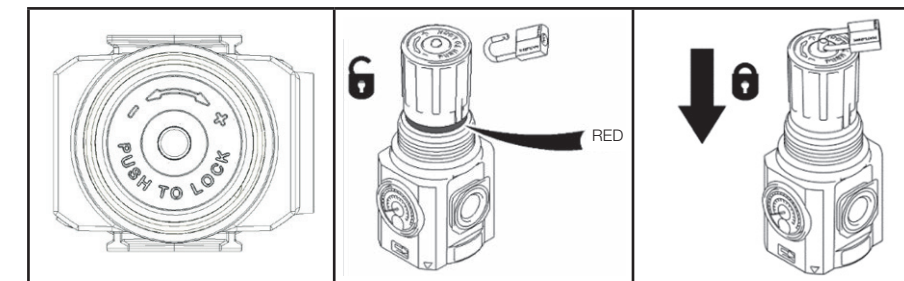

Accessories – 84/82 Series	
Part No.	Description
840055-01KIT	Padlock kit
840055-02KIT	Hasp lock-out device

#### SERVICING

See illustrations below. Use QR code or web link.

#### Servicing-Regulator

- R-5.1 Unscrew bottom plug using socket as shown and remove spring and valve
- R-5.2 Replace all damaged seal components with the corresponding component from the elastomer kit.
- R-5.3 Valve body is separated from valve stem by pushing the valve body end against a hard surface to pop the stem lose and then pull the stem out of body. Push the stem into new valve body until it snaps into place.
- R-5.4 Lubricate valve stem o-ring, valve body o-ring, bottom plug o-ring, and the bottom plug valve bore with a light coat of good quality o-ring grease.
- R-5.5 Reassemble the unit
- R-5.6 Torque the bottom plug to:  
 25-35 IN-LB (2.82-3.95 Nm) for 82 Series (13 mm socket)  
 20-30 IN-LB (2.26-3.39 Nm) for 84 Series (25 mm socket)

#### TABLE 1

Series	Temperature Range	Service Kit	
		82 Series	84 Series
Standard (Transparent Bowl)	-10°C to +60°C	FRLB2-KIT	FRLB84-KIT
Standard (Metal Bowl)	-20°C to +65°C		
Standard (Transparent Bowl) Non-Relieving	-10°C to +60°C		FRLB84NR-KIT
Standard (Metal Bowl) Non-Relieving	-20°C to +65°C		
Preceded by 'L' (Rail approved)	-40°C to +80°C *		L-FRLB84-KIT
Preceded by 'H' (Extreme Temp.)	-40°C to +80°C **		H-FRLB84NR-KIT
Preceded by 'H' (Extreme Temp.) Non-Relieving	-40°C to +80°C **		

Note: Service Kits contain soft seals only, for replacement elements see separate table

\* Excludes all Lubricators(L), all Shut-off Valves (T), 17bar spring not currently offered for B&R units

\*\*HLB4 =, -34°C to +65 and the HT84°C =, -20°C to +80°C

All Variants preceded by 'H' have a broader operating temperature range than the standard series

#### Servicing-Filter-regulator

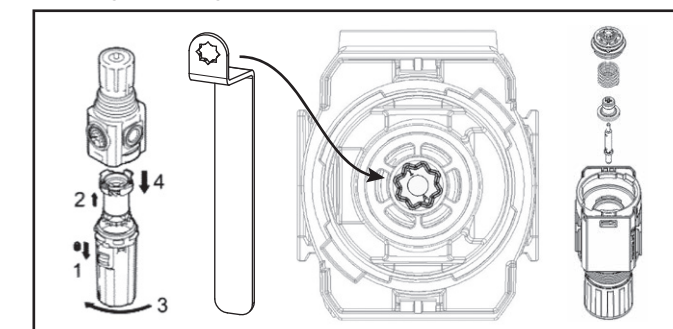

- R-6.1 Remove bowl per GI-7.3, unscrew valve retainer using spanner from FRLB kit, and remove spring & valve
- R-6.2 Replace all damaged seal components with the corresponding component from the elastomer kit.
- R-6.3 Valve body is separated from valve stem by pushing the valve body end against a hard surface to pop the stem lose and then pull the stem out of body. Push the stem into new valve body until it snaps into place.
- R-6.4 Lubricate valve stem o-ring, valve body o-ring, bottom plug o-ring, and the valve retainer bore with a light coat of good quality o-ring grease.
- R-6.5 Reassemble the unit
- R-6.6 Reference valve retainer torque: 18-22 IN-LB (2.03-2.49 Nm) for 82 Series  
 20-30 IN-LB (2.26-3.39 Nm) for 84 Series
- R-6.7 Reinstall the bowl per GI-7.3



### Changing Diaphragm-Filter/regulator and Regulator

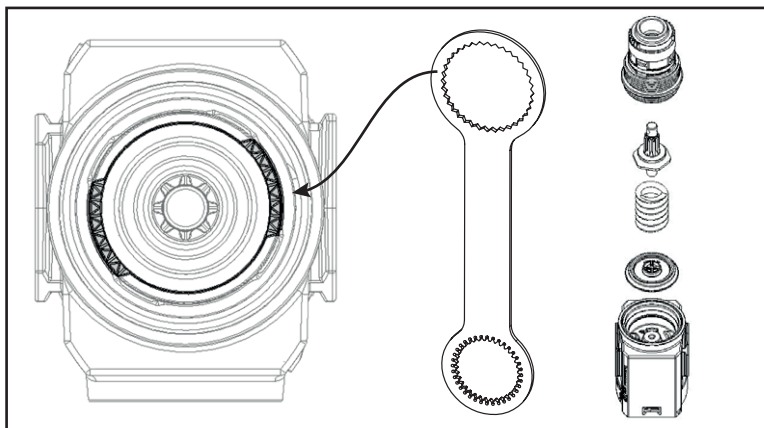

- R-7.1 Pull off the knob
- R-7.2 Use the spanner from the FRLB kit to remove the bonnet
- R-7.3 Remove the diaphragm, adjusting screw, and spring
- R-7.4 Pull apart the diaphragm seal and spring rest
- R-7.5 Push the new seal completely onto the springrest, the springrest will fit into the ribs of the seal and the inside edge of the seal will be below the top of the springrest post
- R-7.6 Reference bonnet torque: 80-110 IN-LB (10.2-12.4 Nm) for 82 Series  
132-177 IN-LB (15-20 Nm) for 84 Series

### Changing Gauge-Filter/regulator and Regulator

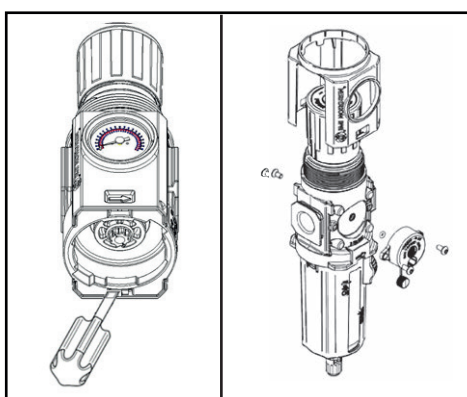

- R-8.1 Use a flat-blade screwdriver to push out both cover tabs and remove the cover.
- R-8.2 Remove the gauge screws and gauge.
- R-8.3 Install the corresponding replacement gauge.
- R-8.4 Torque the gauge screws to:  
3.0-6.0 IN-LB (0.34-0.68 Nm) for 82 Series  
7.0-16.0 IN-LB (0.8-1.8 Nm) for 84 Series
- R-8.5 Install cover ensuring tabs snap into place.

### Moving Gauge Right to Left Flow-Filter/regulator and Regulator

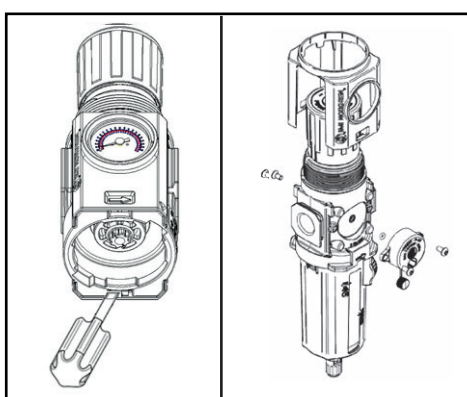

- R-9.1 Use a flat-blade screwdriver to push out both cover tabs and remove the cover.
- R-9.2 Remove the plug from the back side of the unit.
- R-9.3 Remove the gauge screws and gauge.
- R-9.4 Install the gauge on the side of unit that the plug was installed.
- R-9.5 Torque the gauge screws to:  
3.0-6.0 IN-LB (0.34-0.68 Nm) for 82 Series  
7.0-16.0 IN-LB (0.8-1.8 Nm) for 84 Series
- R-9.6 Install the plug on the side of unit that the gauge was originally installed.  
Install cover ensuring tabs snap into place.
- R-9.7 Torque the plug to:  
22.1-26.6 IN-LB (2.50-3.00 Nm)
- R-9.8 Install cover ensuring tabs snap into place.

Replacement Parts-Gauges and Gauge Adaptors				
Part No.	82 Series	84 series	L Version (Rail Approved)	H Version (Extreme Temp.)
Integrated gauge (10 bar) kit	820073-01KIT	840073-01KIT	L840073-01KIT	H840073-01KIT
Integrated gauge (20 bar) kit	820073-02KIT	840073-02KIT	L840073-02KIT	H840073-02KIT
Integrated gauge (4 bar) kit	820073-03KIT			
Gauge adaptor kit 1/8" NPT	820100-01KIT	840100-01KIT	L840100-01KIT	H840100-01KIT
Gauge adaptor kit Rc1/8	820100-02KIT	840100-02KIT	L840100-02KIT	H840100-02KIT

Attention: Using integrated gauge in connecting with L- and H-version, the temperaturerange of the units change to -20°C to +65°C

## Lubricator

### Lubricator-Oil level

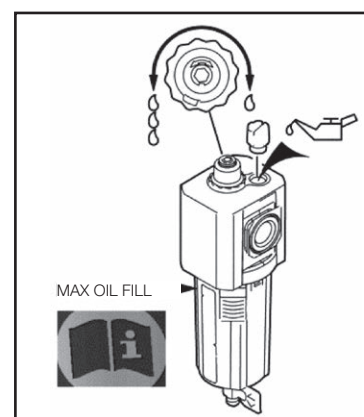

### Servicing-Bowl Replacement

- L-1 Remove and install bowl per GI-7.3.

### Servicing-Lubricator Sight Dome Replacement

- L-2.1 Remove the sight dome and sight dome seal
- L-2.2 Lubricate the new sight dome seal with a light coat of good quality o-ring grease
- L-2.3 Install the sight dome and torque to 20.0-25.0 IN-LB (2.26-2.82 Nm) with a 1" socket

Spares-82/84 Series	
Part No.	Description
840055-50KIT	Micro-fog Sight dome kit
840055-51KIT	Oil-fog Sight dome kit

Spares-84 Series	
Part No.	Description
840003-52KIT	Metal bowl and sight glass with drain plug (closed bottom)
840025-52KIT	Guarded bowl with drain plug (closed bottom)

Spares-82 Series	
Part No.	Description
820003-52KIT	Metal bowl and sight glass with drain plug (closed bottom)
820025-52KIT	Guarded bowl with drain plug (closed bottom)

## Single Unit Bracket

### Mounting bracket options

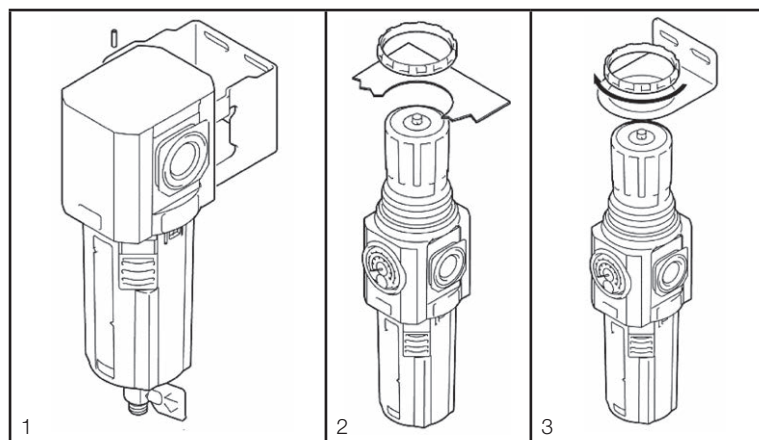

Accessories: Brackets				
Part No.	82 Series	84 series	L Version (Rail Approved)	H Version (Extreme Temp.)
Mounting Bracket	820024-50KIT (1)	840024-50KIT (1)		840024-50KIT (1)
Panel Nut	820048-89KIT (2)	840048-89KIT (2)		840048-89KIT (2)
Neck mount bracket and panel nut	820068-51KIT (3)	840068-51KIT (3)		840068-51KIT (3)

### 82 Series

**Recommended Panel Hole Size:**  
ø1.427" to 1.447" (36.25 to 36.75 mm)  
**Panel Thickness:**  
up to 0.16" (4 mm)

### 84 Series

**Recommended Panel Hole Size:**  
ø2.165" to 2.245" (55 to 57 mm)  
**Panel Thickness:**  
0.06" to 0.25" (2 to 6 mm)

## Recommended Quickclamp Locations

84 Series

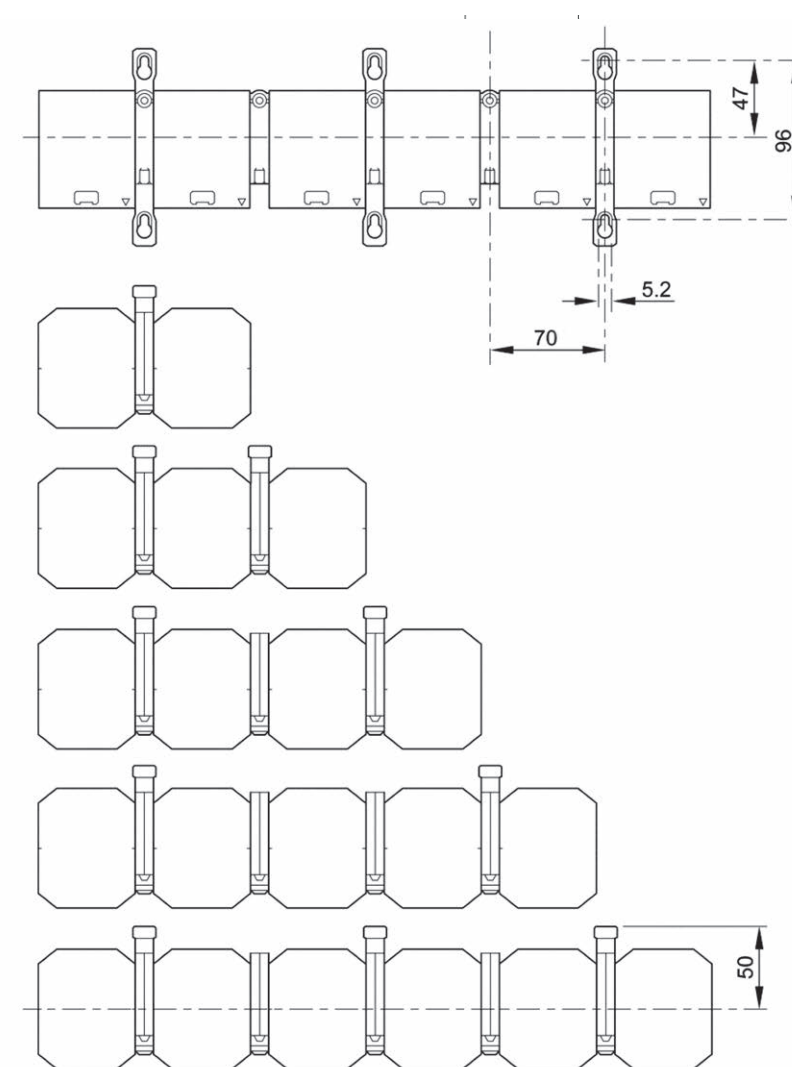

82 Series

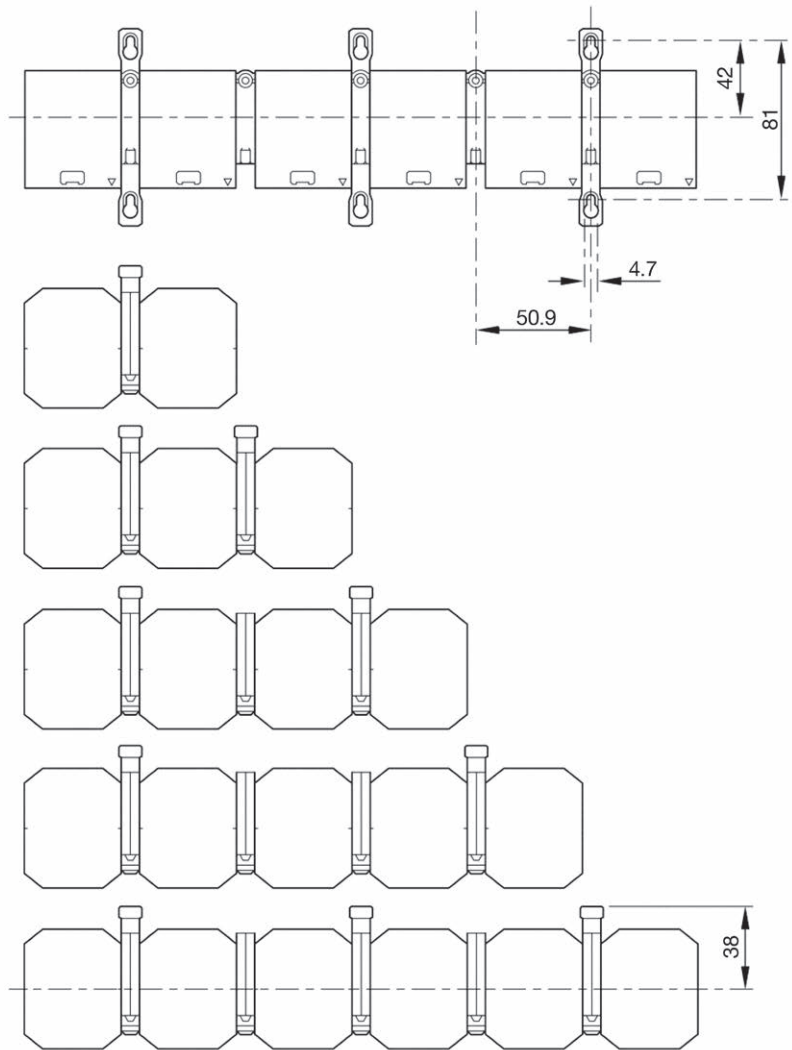

\* Dimensions do not apply to smooth start dump valves.

## Quickclamp

### Quickclamp connection

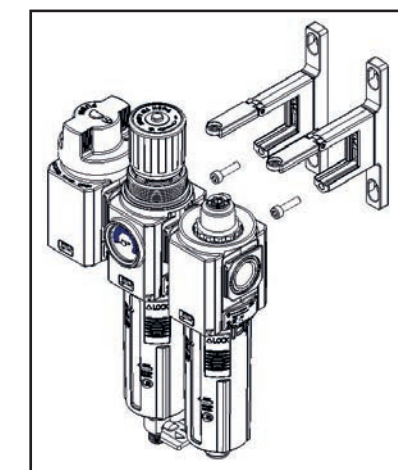

Accessories: Quickclamp				
Part No.	82 Series	84 series	L Version (Rail Approved)	H Version (Extreme Temp.)
Connecting clamp	820014-51KIT	840014-51KIT	L840014-51KIT	H840014-51KIT
Connecting clamp c/w Bracket	820014-52KIT	840014-52KIT	L840014-52KIT	H840014-52KIT

19.5-15.9 IN-LB (1.8-2.2 Nm) 3mm Hex Ddrive

EXCLUDED FROM THE ATEX STATEMENT BELOW ARE P82/P84 VARIANTS EXCEPT ONES SHOWN BELOW. ADDITIONALLY ALL B84 OR R84 PART NUMBERS ENDING IN 'E' ALONG WITH THE Q84-\*\*\* AS ALL THESE VARIANTS ARE FITTED WITH THE INTEGRATED ELECTRONIC PRESSURE SENSOR.

### ATEX Declaration of conformity

#### EU Declaration of conformity (DoC) 2014/34/EU

**Product:** Excelon® Plus T84, F84, R84, B84, T82, F82, R82, B82, LF84G, LF84C, LF84V, LB84G, LR84G HF84G, HF84C, HF84V, HB84G, HR84G, HT84T  
**P-Valves:** P82C-\*\*A-NNN, P82F-\*\*A-NNN, P84C-\*\*A-NNN, P84F-\*\*A-NNN

#### Manufacturers:

- Norgren Manufacturing de Mexico SA de CV  
Av. de la Montaña 120 Parque Industrial Querétaro, Santa Rosa Jauregui  
CP 76220 Oro, MX
- Norgren Ltd, Blenheim Way, Fradley Park, Lichfield, Staffordshire, WS13 8SY

We declare that this declaration of conformity is issued under the sole responsibility of the above manufacturer.

2014/34/EU Equipment and protective systems intended for use in potentially explosive atmospheres  
The following harmonised standards and technical specifications have been applied ISO 4414:2010 – Pneumatic fluid power – General rules and safety requirements for systems and their components; ISO 80079-36:2016 – Explosive atmospheres – Part 36: Non-electrical equipment for explosive atmospheres – Basic method and requirements; ISO 80079-37:2016 – Explosive atmospheres Part 37: Non-electrical equipment for explosive atmospheres – Non-electrical type of protection constructional safety "c", control of ignition sources "b", liquid immersion "k".



**Ex h IIC T6 Gb**  
**Ex h IIIC T85°C Db**  
**ATEX Certification No.: NORGREN 18.0001X**

Under certain extreme circumstances, the non-metallic cover may generate an ignition-capable level of electrostatic charge. The equipment shall not be installed in a location where the external conditions are conducive to the build-up of electrostatic charge on such surfaces. Additionally, the equipment shall only be cleaned with a damp cloth.

#### Attestation of Conformity for components in accordance with Directive 2014/34/EU

We confirm the following equipment: All lubricators (Micro-fog and Oil-fog), gauges, connections kits, filter elements, brackets, and porting blocks conform to essential Health & Safety requirements of Directive 2014/34/EU and as such contain no potential ignition hazard for explosive environments.

#### UKCA Declaration Statement

Equipment and Protective Systems intended for use in Potentially Explosive Atmospheres Regulations 2016.

**Product:** Excelon® Plus T84, F84, R84, B84, T82, F82, R82, B82, LF84G, LF84C, LF84V, LB84G, LR84G HF84G, HF84C, HF84V, HB84G, HR84G, HT84T  
**P-Valves:** P82C-\*\*A-NNN, P82F-\*\*A-NNN, P84C-\*\*A-NNN, P84F-\*\*A-NNN

#### Manufacturers:

- Norgren Manufacturing de Mexico SA de CV  
Av. de la Montaña 120 Parque Industrial Querétaro, Santa Rosa Jauregui  
CP 76220 Oro, MX
- Norgren Ltd, Blenheim Way, Fradley Park, Lichfield, Staffordshire, WS13 8SY

We declare that this declaration of conformity is issued under the sole responsibility of the above manufacturer.

Technical Director:  
James Robinson  
2022

